

1000 Series CASTORS

The 1000 Series 1000kg load rating provides an economical alternative to heavier load bearing castors. The ability to be towed at a 6kph by tugs and tractors enables this castor to be used on mobile platforms, aviation trolleys, automotive assembly lines and production manufacturing plants.

The polyurethane cast iron wheel type with a rolling diameter of up to 300mm not only enhances manoeuvrability but decreases rolling resistance. Like most Richmond heavy duty castors, our 1000 series has a precision machined ball race and high tensile steel kingpin to withstand side impact loads.



S6338SLB



Diameter (mm)	Width (mm)	Wheel Type	Wheel Code	Bearing Type	Load Capacity	Height (mm)	Swivel Radius	Rigid Code	Swivel Code	
150	50	Poly Ci	PU659	Ball	900	194	130	R6339	S6338	👤
150	45	Cast Iron	CI601	Ball	1000	194	130	R6319	S6318	
200	50	Poly Ci	PU876	Ball	1000	248	155	R8069	S8068	👤
200	50	Cast Iron	CI852	Ball	1000	248	155	R8089	S8088	
250	50	Poly Ci	PU1056	Ball	1000	300	180	R1020	S1019	👤
300	50	Poly Ci	PU1218	Ball	1000	360	215	R1205	S1204	👤

BRAKE OPTIONS: B = Brake D = 4 Way Directional Lock SLB = Swivel Lock & Brake

To order castors with Brake, 4 Way Directional Lock or Swivel Lock & Brake add B, D or SLB to end of swivel code e.g. S6138B

👤 denotes towable castors.

Baseplate dimensions & drilling patterns for 1000 Series castors

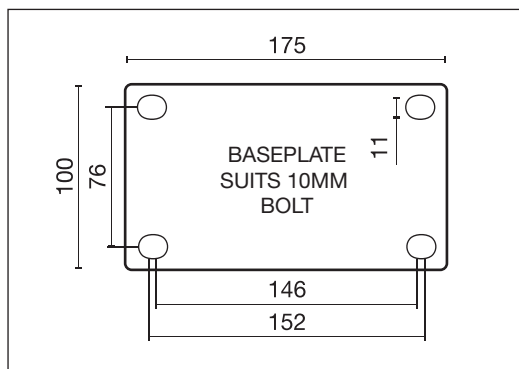

R6319



S1019