



Mini

Wireless Vehicle Detection System

The **e-Loop Mini** replaces traditional wired inductive loops, saving you time and money while increasing reliability.

The **e-Loop Mini** is the little brother of the commercial e-Loop, perfect for domestic applications.



Kit Contents

- 1 x **e-Loop Mini** wireless detection module
- 1 x 12–24VDC single channel transceiver
- 2 x dyna bolts

Features

- Quick and easy installation
- Small compact design (120mm x 120mm x 30mm high)
- Static load capacity 2500kg
- Uses standard 1.5V AA Lithium batteries (not included) providing up to 3 years battery life
- High security 128-bit encryption
- Range up to 50 meters

Specifications

Frequency:	433.39 MHz
Security:	128-bit AES encryption
Range:	up to 50 metres
Battery life:	up to 3 years
Battery type:	Eveready AA Lithium 1.5V x 2 (not Included)
Important:	Use only AA 1.5V Lithium batteries – do not use Alkaline batteries



e-LOOP Mini Fitting Instructions

Before fitting the e-Loop, you will need to fit the 2 x AA batteries and screw the bottom plate to the e-Loop using the M3 screws supplied. Ensure all screws are tight.

Step 1 – Coding e-LOOP Mini

1. Press and hold the CODE button on transceiver until the Red LED illuminates, now release button.
2. Press the CODE button on the e-Loop Mini. The Yellow LED on the e-Loop will flash 3 times to indicate transmission, and the Red LED on the transceiver will flash 3 times to confirm the coding sequence has completed.

Step 2 – Fitting e-LOOP Mini

(Refer to Diagram on the right)

1. Place e-Loop in the desired location and secure base plate into the ground using 2 Dyna bolts (supplied).

NOTE: Never fit near high voltage cables, this can affect the e-Loop's detection capability.

Step 3 – Calibrate e-LOOP Mini

1. Move any metal objects away from the e-Loop, including cordless drills.
2. Press and hold the CODE button and the Yellow LED will flash once, keep your finger on the button until the Red LED flashes twice.
3. Now fit the e-Loop to the base plate using the 4 x Hex Head bolts. After 3 minutes, the Red LED will flash a further 3 times. The e-Loop is now calibrated and ready to use.

System is now ready.

Uncalibrate e-LOOP Mini

1. Press and hold CODE button and the Yellow LED will flash, keep finger on the CODE button until you see the Red LED flash 4 times. Now release button and e-Loop is uncalibrated.

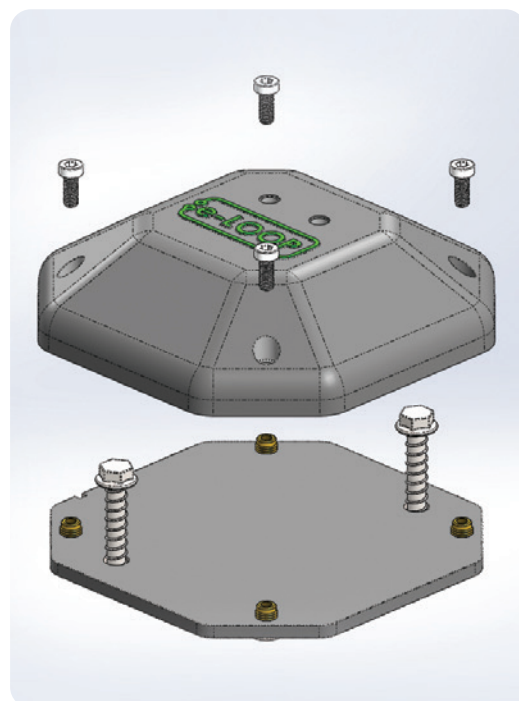



e-TRANS-50

SINGLE CHANNEL TRANSCEIVER

Introducing a bidirectional wireless access control system for gate and door applications.

Featuring a compact design with exceptional range, the e-Trans-50 is designed to manage access control for home and commercial systems.



Features

- Compact design with exceptional range
- SMA connector for standard for optional long-range antenna connection
- Wide Voltage Range: 10-36V DC
- Exceptionally low Current draw: standby 4.5 m/a, active 30 m/a
- Frequency: 433.39 MHz
- Remote storage: 50 remotes, 2 x e-Loops, 2 x Keypads, 2 x Entry Buttons
- Relay: 1-amp contact rating, COM and N/O connections x 1 relay
- Multiple Modes: Pulse, Latch and Hold

Specifications



Voltage:	10-36V DC
Current draw standby:	4.5 m/a
Current draw active:	30 m/a
Frequency:	433.39 MHz
Remote storage:	50 remotes, 2 x e-Loops, 2 x keypads, 2 x entry buttons
Relay:	1-amp contact rating, COM and N/O connections x 1 relay
Modes:	Pulse, Latch and Hold



e-TRANS-50

SINGLE CHANNEL TRANSCEIVER



Coding device

1. To code device press and release **CODE** button. The Code LED will illuminate. 
2. To code remote handset, press the remote button that you want to activate transceiver once. The Code LED will flash, indicating coding sequence. 
3. Press remote button a second time, the Code LED will flash again and the coding sequence is now complete. You can follow on with more remotes, wait 10 seconds for code sequence to automatically exit, or press the coded remote once more to exit. 

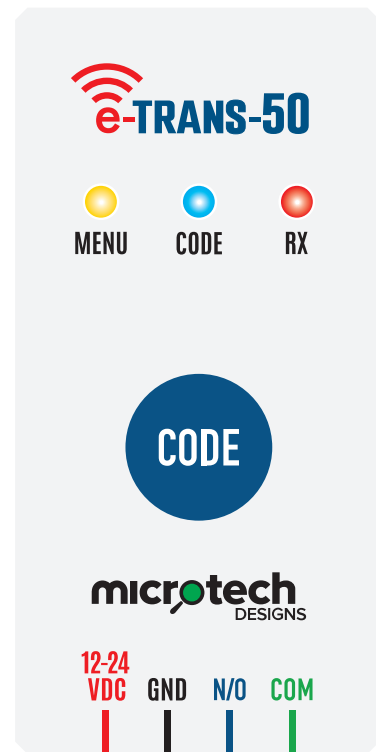
NOTE: The first time a remote is coded into Transceiver, it sets the button allocation for that remote and all future remotes. So if you have chosen button 1 on the first remote, all following remotes will activate from that button no matter which button you coded the following remotes with.



Changing button allocation



1. Press and hold the **CODE** button on the Transceiver, the Code LED will illuminate. 
2. Now take a coded remote and press the button you want the transceiver to work from. All LEDs will flash to indicate changed button allocation. 

All remotes will now work from the new selected button.



Deleting remotes

1. Press and hold code button for 10 seconds. All LEDs will flash 3 times to indicate all remote devices have been cleared. 



To code e-Loop first option

1. Press and release **CODE** button on the Transceiver, the Code LED will illuminate. 
2. Now press the CODE button on the domestic e-Loop, or use the magnet to activate the code button on the commercial e-Loop. The Transceiver and e-Loop will now pair. If pairing was successful, the Code LED will flash 3 times and exit code learn.  If pairing fails, the RX LED will flash 3 times and exit code learn. 

To code e-Loop second option

1. Place antenna of the Transceiver on top of the e-Loop.
2. Now press **CODE** button on the Transceiver. If pairing was successful, the Code LED will flash 3 times and exit code learn.  If pairing fails, the Code LED will stay on as per standard coding sequence. 

To change operational mode

1. Remove the power from the Transceiver by unplugging the terminal block.
2. Now hold the **CODE** button on the Transceiver, then plug in the terminal block. The Menu LED will display. Now release the **CODE** button, the Code LED will also display indicating Pulse mode.  
3. To change mode press **CODE** button, the Menu LED and RX LED will now display indicating Hold mode. 
4. Press **CODE** again and all LEDs will display indicating Latch mode. (By pressing **CODE** button again it will take you back to Pulse mode). Wait 5 seconds and menu will exit back to operational mode. 