

As supplied with standard
M16x65 8.8 commercial bolt

Dimensions without bolt
"Size your M16 8.8 bolt length
to suit your application"

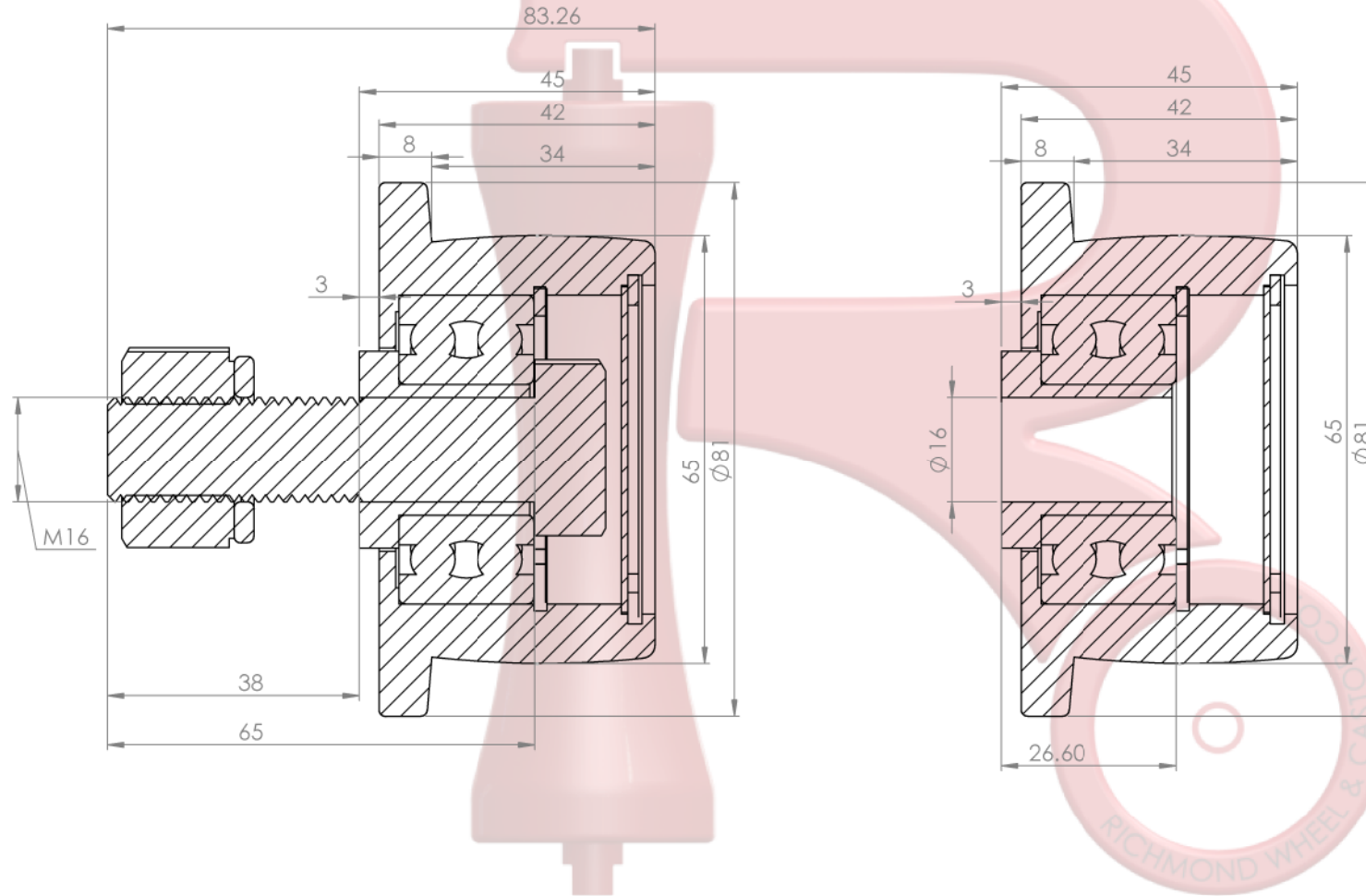

Capacity: 450kg

CUSTOMER APPROVAL:

COMPANY:

SALES PERSON:

NAME:

SIGN:

DATE:

DO NOT SCALE DRAWING

REVISION

FINISH:

PROPRIETARY AND CONFIDENTIAL
THE INFORMATION CONTAINED IN THIS DRAWING
IS THE SOLE PROPERTY OF
Richmond Wheel & Castor Co.
ANY REPRODUCTION IN PART OR AS A WHOLE WITHOUT
THE WRITTEN PERMISSION OF
Richmond Wheel & Castor Co.
IS PROHIBITED.

	NAME	SIGNATURE	DATE
DRAWN	BREON	BWM	8/11/2019
CHK'D	SY	SY	8/11/2019
APP'VD	RAY	RW	8/11/2019
MFG	SY	SY	8/11/2019
Q.A	BARRY	BN	8/11/2019
UNLESS OTHERWISE SPECIFIED: DIMENSIONS ARE IN MILLIMETERS TOLERANCES TO ±.25MM		DEBUR AND BREAK SHARP EDGES	



TITLE:

**RICHMOND WHEEL &
CASTOR CO.**

DWG NO.

BTSF65X34M16

A3

WEIGHT:

SHEET 2 OF 11